



SICMEMOTORI

Technical Catalogue

Code C-AD-355-560-E-10

Large three-phase squirrel cage
asynchronous motors
AD Series

250kW ÷ 1500kw (1500rpm)

for inverter duty



A.C. MOTORS FRAMES 355-560



Declaration of conformity

The motors described in this catalogue satisfy the essential requisites of the following Directives:

- 93/68/CEE Low Voltage Directive

Reference has also been made to the following directives, specifically for the reasons listed as follows:

- EMC 89/336/EEC (Electromagnetic Compatibility) Directive

- 2006/42/CE Machinery Directive

The electric motors/generators are components that are incorporated into other machines, systems and plants and therefore the resulting EMC behaviour is under the responsibility of the Manufacturer of the machine or plant incorporating the motor/generator.

With reference to the 2006/42/EC Directive, it must be specified that the motors/generators must be installed in compliance with the installation instructions and cannot be put into service until the machine in which they are incorporated has been declared in compliance with the 2006/42/EC Machinery Directive.

SICMEMOTORI, among the European leaders for variable speed applications, presents this series of large three-phase heavy duty asynchronous motors, expressly designed for inverter duty. Designing and manufacturing characteristics, together with materials utilised for the construction of these motors, make this series one of the most advanced actually available on the market

Main technical features

Frames 355-560

Squirrel cage rotor

Class F insulation

Class F temperature rise when inverter supplied

Class B temperature rise when grid connected

Insulation and impregnation expressly designed for inverter duty

Dimensions according to IEC 60072 Std.

Ratings and performances according to IEC 60034-1 Std.

Degree of protection IP55 (IEC 60034-5 Std.)

Type of cooling IC411 and IC416 (IEC 60034-6 Std.)

Terminal box (degree of protection IP55) on top

Mounting arrangements IM1001 (B3), IM2001 (B35), IM3011(V1) and derivated (IEC 60034-7 Std.)

Half-key balancing

Metallic name plate

Low noise level (IEC 60034-9 Std.)

Constant torque speed regulation (with inverter supply) down to 25Hz for IC411 selfventilated motors

Constant torque speed regulation (with inverter supply) down to 5Hz for IC416 forced ventilated motors

Constant power speed regulation (with inverter supply) up to 80Hz (max. speed must be compatible with table at page 15).

Final colour grey RAL7037

All motors are in conformity with European Directives and are CE marked.

Motors can run with voltage variation of $\pm 10\%$ and frequency variation of $\pm 5\%$ with a maximum combined variation of $\pm 10\%$, with temperature rise in compliance with IEC Standards.

Ratings and technical data

The tables of technical data are referred to an ambient temperature of 40°C and an altitude up to 1000 m.a.s.l..

In different environmental conditions output ratings vary, and are obtainable by applying the factors showed in table 6, maintaining the temperature rise within the B insulation class (F insulation class when inverter supplied).

Altitude m.a.s.l.	Ambient temperature (°C)					
	30	30-40	45	50	55	60
<= 1000	1.06	1	0.97	0.94	0.90	0.87
1500	1.04	0.97	0.94	0.91	0.87	0.84
2000	1	0.95	0.92	0.88	0.84	0.81
3000	0.96	0.89	0.86	0.82	0.78	0.74
4000	0.91	0.84	0.80	0.76	0.72	0.67

Efficiency

Motors frames 355 (2-4-6 poles) described in this catalogue respond to the rules introduced by IEC60034-30 Standards in terms of efficiency; efficiency class is IE1 (former Eff.2 Class).

On request, motors 355 with efficiency class IE2 (former Eff.1 class) are available.

Bigger frames, for which IEC60034-30 Standards do not state any specific value, are anyway high efficiency motors.

2 Poles - 50Hz - 3000rpm (technical data based on 400V – 50Hz)

		Rated output power P_N	Rated current I_N			Full-load speed n_N	Full-load power factor	Full-load efficiency η		Full-load torque M_N	Starting current I_s/I_N	Starting torque M_s/M_N	Pull-out torque M_k/M_N	Sound pressure level	Moment of inertia $J = \frac{1}{4}GD^2$	Weight foot mounted	
			kW	380V	400V			420V	100%								75%
				A	A			A									
AD 355 M	2	250	440	418	398	2.985	0,90	96,1	95,8	800	6,8	2,1	3,1	90,0	3,296	1.690	
AD 355 L	2	280	495	470	448	2.980	0,90	95,8	95,6	898	5,4	1,6	2,6	90,0	3,489	1.775	
AD 355 Lx	2	315	555	527	502	2.990	0,90	96,4	96,1	1.007	7,4	1,9	3,4	90,0	3,950	1.860	
AD 355Ly	2	355	632	601	572	2.975	0,89	96,2	96,1	1.140	5,4	1,6	2,7	90,0	4,800	2.050	
AD 400 M	2	400	702	667	635	2.990	0,90	96,2	95,9	1.278	7,6	1,7	2,7	94,0	7,95	2.950	
AD 400 Mx	2	450	793	753	717	2.990	0,90	95,8	95,5	1.438	7,5	1,5	2,7	94,0	8,60	3.200	
AD 400 L	2	500	873	829	790	2.990	0,91	95,9	95,6	1.597	7,3	1,5	2,8	94,0	9,60	3.340	
			400V A	690V A													
AD 400 Lx	2	560	911	870	829	2.980	0,92	96,4	96,1	1.795	7,0	1,5	2,0	90,0	8,60	3.200	
AD 400 Ly	2	630	1.025	970	929	2.980	0,92	96,4	96,1	2.019	7,0	1,5	2,0	90,0	9,60	3.490	
AD 400 Lz	2	710	1.158	1.117	1.076	2.980	0,92	96,5	96,2	2.276	7,0	1,5	2,0	90,0	11,00	3.660	
AD 450 M	2																
AD 450 Mx	2	750	---	707	666	2.985	0,92	96,5	96,2	2.400	7,0	1,0	2,0	93,0	18,00	4.200	
AD 450 L	2	800	---	754	713	2.985	0,92	96,5	96,2	2.560	7,0	1,0	2,0	93,0	19,00	4.400	
AD 450 Lx	2	900	---	847	806	2.985	0,92	96,7	96,4	2.880	7,0	1,0	2,0	93,0	21,00	4.650	
AD 450 Ly	2	1000	---	941	900	2.985	0,92	96,7	96,4	3.200	7,0	1,0	2,0	93,0	23,00	4.950	
AD 450 Lz	2																
AD 500 M	2																
AD 500 L	2																
AD 500 Lx	2																
AD 560 M	2																
AD 560 L	2																
AD 560 Lx	2																

2 Poles - 60Hz - 3600rpm (technical data based on 480V – 60Hz)

		Rated output power P_N	Rated current I_N	Full-load speed n_N	Full-load torque M_N	Sound pressure level	Rated output power P_N	Rated current I_N	Full-load speed n_N	Full-load torque M_N	Sound pressure level	Rated output power P_N	Rated current I_N	Full-load speed n_N	Full-load torque M_N	Sound pressure level									
																	440V-60Hz			460V-60Hz			480V-60Hz		
																	kW	A	rpm	Nm	dB(A)	kW	A	rpm	Nm
AD 355 M	2	288	439	3580	767	92,0	300	436	3580	800	92,0	300	418	3580	800	92,0									
AD 355 L	2	322	494	3580	859	92,0	336	490	3580	896	92,0	336	470	3580	896	92,0									
AD 355 Lx	2	362	553	3590	964	92,0	378	550	3590	1006	92,0	378	527	3590	1006	92,0									
AD 355 Ly	2	408	631	3570	1092	92,0	426	626	3570	1140	92,0	426	601	3570	1140	92,0									
AD 400 M	2	460	700	3590	1224	96,0	480	696	3590	1277	96,0	480	667	3590	1277	96,0									
AD 400 Mx	2	518	791	3590	1377	96,0	540	785	3590	1437	96,0	540	753	3590	1437	96,0									
AD 400 L	2	575	870	3590	1530	96,0	600	865	3590	1596	96,0	600	829	3590	1596	96,0									
AD 400 Lx	2	644	957	3580	1718	92,0	672	950	3580	1793	92,0	672	911	3580	1793	92,0									
AD 400Ly	2	725	1076	3580	1933	92,0	756	1069	3580	2017	92,0	756	1025	3580	2017	92,0									
AD 400Lz	2	817	1216	3580	2178	92,0	852	1208	3580	2273	92,0	852	1158	3580	2273	92,0									
AD 450M	2																								
AD 450Mx	2																								
AD 450L	2																								
AD 450Lx	2																								
AD 450Ly	2																								
AD 450Lz	2																								
AD 500M	2																								
AD 500L	2																								
AD 500Lx	2																								
AD 560M	2																								
AD 560L	2																								
AD 560Lx	2																								

4 Poles – 50HZ - 1500rpm (technical data based on 400V – 50Hz)

		Rated output power P_N	Rated current I_N			Full-load speed n_N	Full-load power factor	Full-load efficiency η		Full-load torque M_N	Starting current I_s/I_N	Starting torque M_s/M_N	Pull-out torque M_k/M_N	Sound pressure level	Moment of inertia $J = \frac{1}{4}GD^2$	Weight foot mounted	
			kW	380V	400V			420V	100%								75%
				A	A			A									
AD 355 M	4	250	445	423	403	1490	0,89	95,7	95,8	1603	6,2	2,9	3,2	84,0	7,164	1720	
AD 355 L	4	280	499	474	451	1490	0,89	95,6	95,2	1795	6,7	2,6	3,2	84,0	7,903	1850	
AD 355 Lx	4	315	560	532	507	1490	0,89	96,1	96,0	2019	7,5	2,4	3,2	84,0	8,702	1950	
AD 355Ly	4	355	635	603	575	1485	0,89	96,0	95,9	2283	7,8	2,3	3,4	84,0	11,200	2000	
AD 400 M	4	400	708	673	641	1490	0,89	96,1	95,8	2564	6,4	1,3	2,9	87,0	14,900	3000	
AD 400 Mx	4	450	793	753	717	1490	0,90	95,9	95,5	2885	6,6	1,5	3,1	87,0	16,100	3150	
AD 400 L	4	500	878	834	794	1490	0,90	96,5	96,3	3205	6,2	1,3	2,9	89,0	17,300	3300	
			400V	690V													
			A	A													
AD 400 Lx	4	560	941	546	1485	0,89	96,3	95,8	3602	7,0	1,5	2,0	85,0	17,100	3360		
AD 400 Ly	4	630	1059	614	1485	0,89	96,5	96,3	4052	7,0	1,5	2,0	85,0	18,500	3430		
AD 400 Lz	4	710	1195	691	1485	0,89	96,5	96,2	4566	7,0	1,5	2,0	85,0	21,100	3620		
AD 450 M	4	710	1193	692	1490	0,89	96,5	96,2	4551	7,0	1,2	2,0	90,0	28,000	4500		
AD 450 Mx	4	750	1260	731	1490	0,89	96,5	96,2	4808	7,0	1,2	2,0	90,0	31,000	4600		
AD 450 L	4	800	1343	779	1490	0,89	96,6	96,3	5128	7,0	1,2	2,0	90,0	33,800	4700		
AD 450 Lx	4	850	---	827	1490	0,89	96,6	96,3	5448	7,0	1,2	2,0	90,0	35,000	4800		
AD 450 Ly	4	900	---	874	1490	0,89	96,8	96,5	5769	7,0	1,2	2,0	90,0	36,900	4900		
AD 450 Lz	4																
AD 500 M	4	1000	---	971	1490	0,90	97,0	96,5	6410	7,0	0,9	2,0	94,0	60,000	6750		
AD 500 L	4	1120	---	1074	1490	0,90	97,0	96,7	7179	7,0	0,9	2,0	94,0	68,000	7250		
AD 500 Lx	4	1200	---	1198	1490	0,90	97,0	96,7	8012	7,0	0,9	2,0	94,0	78,000	7500		
AD 560 M	4	1400	---	1378	1490	0,89	95,5	95,2	8973	7,0	0,9	2,0	96,0	78,500	8570		
AD 560 L	4	1500	---	1475	1490	0,89	95,6	95,3	9614	7,0	0,9	2,0	96,0	86,500	9000		
AD 560 Lx	4																

4 Poles - 60Hz - 1800rpm (technical data based on 480V – 60Hz)

		Rated output power P_N	Rated current I_N	Full-load speed n_N	Full-load torque M_N	Sound pressure level	Rated output power P_N	Rated current I_N	Full-load speed n_N	Full-load torque M_N	Sound pressure level	Rated output power P_N	Rated current I_N	Full-load speed n_N	Full-load torque M_N	Sound pressure level									
																	440V-60Hz			460V-60Hz			480V-60Hz		
																	kW	A	rpm	Nm	dB(A)	kW	A	rpm	Nm
AD 355 M	4	288	444	1790	1534	86,0	300	441	1790	1601	86,0	300	423	1790	1601	86,0									
AD 355 L	4	322	498	1790	1718	86,0	336	494	1790	1793	86,0	336	474	1790	1793	86,0									
AD 355 Lx	4	362	559	1790	1933	86,0	378	555	1790	2017	86,0	378	532	1790	2017	86,0									
AD 355 Ly	4	408	634	1780	2190	86,0	426	629	1780	2286	86,0	426	603	1780	2286	86,0									
AD 400 M	4	460	707	1790	2454	89,0	480	702	1790	2561	89,0	480	673	1790	2561	89,0									
AD 400 Mx	4	518	791	1790	2761	89,0	540	785	1790	2881	89,0	540	753	1790	2881	89,0									
AD 400 L	4	575	876	1790	3068	91,0	600	870	1790	3201	91,0	600	834	1790	3201	91,0									
AD 400 Lx	4	644	988	1780	3455	87,0	672	981	1780	3605	87,0	672	941	1780	3605	87,0									
AD 400Ly	4	725	1112	1780	3887	87,0	756	1105	1780	4056	87,0	756	1059	1780	4056	87,0									
AD 400Lz	4	817	1255	1780	4381	87,0	852	1246	1780	4571	87,0	852	1195	1780	4571	87,0									
AD 450M	4	817	1247	1790	4356	92,0	852	1245	1790	4546	92,0	852	1193	1790	4546	92,0									
AD 450Mx	4	863	1318	1790	4602	92,0	900	1315	1790	4802	92,0	900	1260	1790	4802	92,0									
AD 450L	4	920	1414	1790	4908	92,0	960	1405	1790	5122	92,0	960	1347	1790	5122	92,0									
AD 450Lx	4																								
AD 450Ly	4																								
AD 450Lz	4																								
AD 500M	4																								
AD 500L	4																								
AD 500Lx	4																								
AD 560M	4																								
AD 560L	4																								
AD 560Lx	4																								

6 Poles – 50HZ - 1000rpm (technical data based on 400V – 50Hz)

	Rated output power P_N	Rated current I_N			Full-load speed n_N	Full-load power factor	Full-load efficiency η		Full-load torque M_N	Starting current I_s/I_N	Starting torque M_s/M_N	Pull-out torque M_k/M_N	Sound pressure level	Moment of inertia $J = \frac{1}{4}GD^2$	Weight foot mounted	
		kW	380V	400V			420V	100%								75%
			A	A			A									
AD 355 M	6	160	283	269	256	990	0,90	95,5	95,4	1544	7,1	2,2	3,2	72,0	9,27	1690
AD 355 Mx	6	180	316	300	286	990	0,91	95,6	95,4	1737	7,0	1,7	3,1	72,0	9,52	1770
AD 355 My	6	200	354	336	320	990	0,90	96,1	95,9	1930	7,0	1,9	3,2	73,0	10,80	1870
AD 355 L	6	225	397	377	359	990	0,90	95,9	95,8	2171	6,8	1,7	3,0	73,0	11,10	1900
AD 355 Lx	6	250	442	420	400	990	0,90	96,0	96,0	2412	7,1	1,9	3,2	73,0	11,80	1980
AD 355Ly	6	280	511	485	462	990	0,87	96,0	95,6	2702	6,6	2,2	2,9	73,0	12,90	2150
AD 400 M	6	315	566	538	512	990	0,88	96,1	96,1	3859	6,6	1,4	3,0	76,0	21,20	3410
AD 400 Mx	6	355	637	605	576	995	0,88	96,5	96,2	4320	6,7	1,2	3,1	76,0	23,50	3650
AD 400 L	6	400	719	683	650	995	0,88	95,8	95,6	4799	7,3	1,5	3,3	76,0	26,40	3700
			400V	690V												
			A	A												
AD 400 Lx	6	450	783	743	714	990	0,86	96,5	96,1	4341	6,8	1,5	1,8	82,0	23,50	3200
AD 400 Ly	6	500	870	827	794	990	0,86	95,8	95,4	4824	6,8	1,5	1,8	82,0	26,40	3490
AD 400 Lz	6	560	974	924	884	990	0,86	96,5	96,1	5403	6,5	1,5	1,8	82,0	28,80	3660
AD 450 M	6															
AD 450 Mx	6															
AD 450 L	6	630	1106	1056	1014	995	0,85	96,7	96,3	6047	6,5	1,4	1,8	86,0	45,10	4700
AD 450 Lx	6	710	1251	1191	1149	995	0,85	96,7	96,3	6815	6,5	1,4	1,8	86,0	48,60	5100
AD 450 Ly	6	750	1302	1242	1199	995	0,87	95,6	95,2	7199	7,0	1,2	2,5	86,0	51,33	5300
AD 450 Lz	6	800	1408	1348	1306	995	0,85	96,7	96,3	7679	6,5	1,4	1,8	86,0	54,20	5500
AD 500 M	6	900	---	---	903	995	0,86	97,0	96,6	8639	6,5	1,0	1,8	88,0	89,00	6855
AD 500 L	6	1000	---	---	1003	995	0,86	97,0	96,6	9598	6,5	1,0	1,8	88,0	98,00	7250
AD 500 Lx	6	1120	---	---	1123	995	0,86	97,0	96,6	10750	6,5	1,0	1,8	88,0	105,00	7350
AD 560 M	6	1250	---	---	1254	995	0,86	97,0	96,6	11998	6,5	0,8	1,8	88,0	105,00	8200
AD 560 L	6	1400	---	---	1405	995	0,86	97,0	96,6	13438	6,5	0,8	1,8	88,0	130,00	8400
AD 560 Lx	6															

6 Poles - 60Hz - 1200rpm (technical data based on 480V – 60Hz)

	Rated output power P_N	Rated current I_N			Full-load speed n_N	Full-load torque M_N	Sound pressure level	Rated output power P_N			Rated current I_N			Full-load speed n_N	Full-load torque M_N	Sound pressure level
		440V-60Hz						460V-60Hz			480V-60Hz					
		kW	A	rpm				Nm	dB(A)	kW	A	rpm	Nm			
AD 355 M	6	184	282	1190	1477	74,0	192	281	1190	1541	74,0	192	269	1190	1541	74,0
AD 355 Mx	6	207	315	1190	1661	74,0	216	313	1190	1733	74,0	216	300	1190	1733	74,0
AD 355 My	6	230	353	1190	1846	75,0	240	350	1190	1926	75,0	240	336	1190	1926	75,0
AD 355 L	6	259	396	1190	2077	75,0	270	393	1190	2167	75,0	270	377	1190	2167	75,0
AD 355 Lx	6	288	441	1190	2307	75,0	300	438	1190	2408	75,0	300	420	1190	2408	75,0
AD 355 Ly	6	322	509	1190	2584	75,0	336	506	1190	2696	75,0	336	485	1190	2696	75,0
AD 400 M	6	362	565	1190	3692	78,0	480	561	1190	3852	78,0	480	538	1190	3852	78,0
AD 400 Mx	6	408	635	1190	4153	78,0	540	631	1190	4334	78,0	540	605	1190	4334	78,0
AD 400 L	6	460	717	1190	4615	78,0	600	712	1190	4815	78,0	600	683	1190	4815	78,0
AD 400 Lx	6	518	818	1190	4153	84,0	540	817	1190	4334	84,0	540	783	1190	4334	84,0
AD 400Ly	6	575	916	1190	4615	84,0	600	907	1190	4815	84,0	600	870	1190	4815	84,0
AD 400Lz	6	644	1018	1190	5168	84,0	672	1016	1190	5393	84,0	672	974	1190	5393	84,0
AD 450M	6															
AD 450Mx	6															
AD 450L	6	725	1157	1190	5814	88,0	756	1154	1190	6067	88,0	756	1106	1190	6067	88,0
AD 450Lx	6	817	1303	1190	6553	88,0	852	1301	1190	6837	88,0	852	1247	1190	6837	88,0
AD 450Ly	6	863	1361	1190	6922	88,0	900	1358	1190	7223	88,0	900	1302	1190	7223	88,0
AD 450Lz	6	920	1479	1190	7383	88,0	960	1469	1190	7704	88,0	960	1408	1190	7704	88,0
AD 500M	6															
AD 500L	6															
AD 500Lx	6															
AD 560M	6															
AD 560L	6															
AD 560Lx	6															

8 Poles – 50HZ - 750rpm (technical data based on 400V – 50Hz)

	Rated output power P_N	Rated current I_N			Full-load speed n_N	Full-load power factor	Full-load efficiency η		Full-load torque M_N	Starting current I_s/I_N	Starting torque M_s/M_N	Pull-out torque M_k/M_N	Sound pressure level	Moment of inertia $J = \frac{1}{4}GD^2$	Weight foot mounted	
		kW	380V	400V			420V	100%								75%
			A	A			A									
AD 355 M	8	132	252	239	228	745	0,84	95,0	94,6	1693	6,6	1,9	3,1	72,0	12,90	1800
AD 355 Mx	8	160	298	283	270	745	0,86	95,3	94,9	2052	5,6	1,6	2,7	72,0	14,30	1890
AD 355 My	8															
AD 355 L	8	180	339	322	307	745	0,85	95,0	94,6	2308	6,0	1,7	2,9	73,0	15,00	1970
AD 355 Lx	8	200	395	375	357	745	0,81	95,2	94,9	2564	5,9	2,1	2,5	73,0	15,90	2040
AD 355Ly	8	225	448	426	406	745	0,80	95,6	95,2	2.885	6,0	2,2	2,5	73,0	17,10	2230
AD 400 M	8	250	499	474	451	745	0,80	95,5	94,9	3205	6,9	1,4	3,4	73,0	27,40	2900
AD 400 Mx	8	280	539	512	488	745	0,83	95,7	95,3	3590	6,5	1,3	3,3	73,0	28,90	3000
AD 400 L	8	315	589	560	533	745	0,85	95,8	95,2	4038	6,5	1,3	3,2	75,0	30,60	3100
			400V	690V												
			A	A												
AD 400 Lx	8	355	671	649	628	740	0,80	95,8	95,6	4582	6,0	1,5	1,8	78,0	24,20	3350
AD 400 Ly	8	400	756	733	712	740	0,80	95,5	95,4	5163	6,0	1,5	1,8	78,0	26,00	3430
AD 400 Lz	8	450	849	826	805	740	0,80	95,6	95,2	5808	6,0	1,5	1,8	78,0	29,00	3760
AD 450 M	8	500	942	919	898	745	0,80	95,8	95,4	6410	5,6	1,2	1,8	82,0	44,10	4750
AD 450 Mx	8	560	1055	1032	1011	745	0,80	95,8	95,4	7179	5,6	1,2	1,8	82,0	49,50	5215
AD 450 L	8	630	1184	1161	1140	745	0,80	96,0	95,6	8076	5,6	1,2	1,8	82,0	54,80	5600
AD 450 Lx	8															
AD 450 Ly	8															
AD 450 Lz	8															
AD 500 M	8	710	1322	1299	1278	745	0,81	96,0	95,6	9102	5,6	1,0	1,8	85,0	88,00	6500
AD 500 L	8	800	1486	1463	1442	745	0,81	96,2	95,8	10256	5,6	1,0	1,8	85,0	92,00	6800
AD 500 Lx	8													105,00		7050
AD 560 M	8	900	---	---	---	745	0,81	96,4	96,2	11537	5,6	0,8	1,8	85,0	135,00	8350
AD 560 L	8	1000	---	---	---	745	0,81	96,5	96,1	12819	5,6	0,8	1,8	85,0	160,00	8550
AD 560 Lx	8															

8 Poles - 60Hz - 900rpm (technical data based on 480V – 60Hz)

	Rated output power P_N	Rated current I_N	Full-load speed n_N	Full-load torque M_N	Sound pressure level	Rated output power P_N		Rated current I_N	Full-load speed n_N	Full-load torque M_N	Sound pressure level	Rated output power P_N		Rated current I_N	Full-load speed n_N	Full-load torque M_N	Sound pressure level											
						kW	A					rpm	Nm					dB(A)	kW	A	rpm	Nm	dB(A)	kW	A	rpm	Nm	dB(A)
AD 355 M	8	152	251	890	1629	74,0	158	249	890	1700	74,0	158	239	890	1700	74,0												
AD 355 Mx	8	184	297	890	1974	74,0	192	295	890	2060	74,0	192	283	890	2060	74,0												
AD 355 My	8																											
AD 355 L	8	207	338	890	2221	75,0	216	336	890	2318	75,0	216	322	890	2318	75,0												
AD 355 Lx	8	230	394	890	2468	75,0	240	391	890	2575	75,0	240	375	890	2575	75,0												
AD 355 Ly	8	259	447	890	2776	75,0	270	444	890	2897	75,0	270	426	890	2897	75,0												
AD 400 M	8	288	498	890	3085	75,0	300	494	890	3219	75,0	300	474	890	3219	75,0												
AD 400 Mx	8	322	538	890	3455	75,0	336	534	890	3605	75,0	336	512	890	3605	75,0												
AD 400 L	8	362	588	890	3887	77,0	378	584	890	4056	77,0	378	560	890	4056	77,0												
AD 400 Lx	8	408	705	890	4381	80,0	426	700	890	4571	80,0	426	671	890	4571	80,0												
AD 400Ly	8	460	794	890	4936	80,0	480	789	890	5151	80,0	480	756	890	5151	80,0												
AD 400Lz	8	518	891	890	5553	80,0	540	886	890	5794	80,0	540	849	890	5794	80,0												
AD 450M	8	575	989	890	6170	84,0	600	983	890	6438	84,0	600	942	890	6438	84,0												
AD 450Mx	8	644	1108	890	6910	84,0	672	1100	890	7211	84,0	672	1055	890	7211	84,0												
AD 450L	8	725	1243	890	7774	84,0	756	1235	890	8112	84,0	756	1184	890	8112	84,0												
AD 450Lx	8																											
AD 450Ly	8																											
AD 450Lz	8																											
AD 500M	8	817	1388	890	8761	87,0	852	1379	890	9142	87,0	852	1322	890	9142	87,0												
AD 500L	8	920	1560	890	9872	87,0	960	1550	890	10301	87,0	960	1486	890	10301	87,0												
AD 500Lx	8	1035	1755	890	11106	87,0	1080	1743	890	11589	87,0	1080	1671	890	11589	87,0												
AD 560M	8																											
AD 560L	8																											
AD 560Lx	8																											

Efficiency

	rated output power P_N kW	full-load efficiency 2 pole – 3000rpm				rated output power P_N kW	full-load efficiency 4 pole – 1500rpm				rated output power P_N kW	full-load efficiency 6 pole – 1000rpm				rated output power P_N kW	full-load efficiency 8 pole – 750rpm			
		125%	100%	75%	50%		125%	100%	75%	50%		125%	100%	75%	50%		125%	100%	75%	50%
		η	η	η	η		η	η	η	η		η	η	η	η		η	η	η	η
AD 355 M	250	95,7	96,1	95,8	94,2	250	95,0	95,7	95,8	94,7	160	95,0	95,5	95,4	93,9	132	94,3	95,0	94,6	92,7
AD 355 Mx											180	95,2	95,6	95,4	93,9	160	95,0	95,3	94,9	92,9
AD 355 My											200	95,7	96,1	95,9	94,7					
AD 355 L	280	95,2	95,8	95,6	94,2	280	95,5	95,6	95,2	94,5	225	95,3	95,9	95,8	94,8	180	94,9	95,0	94,6	92,8
AD 355 Lx	315	96,0	96,4	96,1	94,8	315	95,5	96,1	96,0	94,8	250	95,3	96,0	96,0	94,8	200	94,6	95,2	94,9	93,3
AD 355 Ly	355	95,1	96,2	96,1	95,1	355	95,5	96,0	95,9	94,8	280	95,9	96,0	95,6	93,8	225	95,2	95,6	95,2	93,4
AD 400 M	400	95,6	96,2	95,9	94,9	400	95,6	96,1	95,8	94,4	315	95,5	96,1	96,1	94,9	250	95,4	95,5	94,9	92,8
AD 400 Mx	450	95,2	95,8	95,5	94,5	450	95,6	95,9	95,5	93,9	355	96,2	96,5	96,2	94,7	280	95,6	95,7	95,3	93,5
AD 400 L	500	95,3	95,9	95,6	94,6	500	95,9	96,5	96,3	94,9	400	95,5	95,8	95,6	94,3	315	95,4	95,8	95,2	93,1
AD 400 Lx	560	95,8	96,4	96,1	95,0	560	96,1	96,3	95,8	94,3	450	96,4	96,5	96,1	94,3	355	95,4	95,8	95,6	94,0
AD 400 Ly	630	95,8	96,4	96,1	95,0	630	96,1	96,5	96,3	95,1	500	95,5	95,8	95,4	93,7	400	95,0	95,5	95,4	93,9
AD 400 Lz	710	95,9	96,5	96,2	95,1	710	96,1	96,5	96,2	95,2	560	96,4	96,5	96,1	94,3	450	95,2	95,6	95,2	93,4
AD 450 M						710	96,1	96,5	96,2	95,2	560	96,2	96,6	96,2	94,8	500	95,4	95,8	95,4	93,6
AD 450 Mx	750	95,9	96,5	96,2	95,1	750	96,1	96,5	96,2	95,2					560	95,4	95,8	95,4	93,6	
AD 450 L	800	95,9	96,5	96,2	95,1	800	96,2	96,6	96,3	95,3	630	96,3	96,7	96,3	94,9	630	95,6	96,0	95,6	93,8
AD 450 Lx	900	96,1	96,7	96,4	95,3	850	96,2	96,6	96,3	95,3	710	96,3	96,7	96,3	94,9					
AD 450 Ly	1000	96,1	96,7	96,4	95,3	900	96,4	96,8	96,5	95,5	750	95,2	95,6	95,2	93,8					
AD 450 Lz											800	96,3	96,7	96,3	94,9					
AD 500 M						1000	96,6	97,0	96,7	95,7	900	96,6	97,0	96,6	95,2	710	95,6	96,0	95,6	93,8
AD 500 L						1120	96,6	97,0	96,7	95,7	1000	96,6	97,0	96,6	95,2	800	95,8	96,2	95,8	94,0
AD 500 Lx						1200	96,6	97,0	96,7	95,7	1120	96,6	97,0	96,6	95,2	900	95,8	96,2	95,8	94,0
AD 560 M						1400	95,1	95,5	95,2	94,2	1250	96,6	97,0	96,6	95,2	1000	96,1	96,5	96,1	94,3
AD 560 L						1500	95,2	95,6	95,3	94,3	1400	96,6	97,0	96,6	95,2	1120	96,4	96,8	96,4	94,6
AD 560 Lx															1250	96,6	97,0	96,6	94,8	

All technical details are based on 400V/50Hz

Bearings

Frame size	Poles	Drive end (A-side)			Non drive end (B-side)			
		Ball Bearing	Regreasable Ball Bearings	NU Bearing (on request)	Ball Bearing	Regreasable Bearings	Insulated Bearing	V1 mounting
AD 355	2	-	6317 C3	NU 317	-	6317 C3	6317 MC3 VL0241	7317 B
AD 355	4 - 8	-	6322 C3	NU 322	-	6320 C3	6320 MC3 VL0241	7320 B
AD 400	2	-	6317 C3	NU 317	-	6317 C3	6317 MC3 VL0241	7317 B
AD 400	4 - 8	-	6326 C3	NU 326	-	6326 C3	6326 MC3 VL0241	7326 B
AD 450	2	-	6319 C3	NU 319	-	6319 C3	6319 MC3 VL0241	7319 B
AD 450	4 - 8	-	6328 C3	NU 328	-	6328 C3	6328 MC3 VL0241	7328 B
AD 500	4 - 8	-	6330 C3	NU 330	-	6330 C3	6330 MC3 VL0241	7330 B
AD 560	4 - 8	-	6334 C3	NU 334	-	6330 C3	6330 MC3 VL0241	7330 B

Transport locking: all motors with an “NU bearing” or an “Angular contact bearing” are fitted with a transport locking device to prevent damage to the bearings due to vibrations during transport.

Frequency drive: for all motors driven by a frequency converter an insulated bearing at the NDE side is mounted. For motors in V1 mounting, the insulated bearing is mounted at the DE side, and the “angular contact bearing” at the NDE side

Informations given in tables are indicative, certified values are available on request.

SICMEMOTORI reserves the right to modify designing, technical features and dimensions without prior notice.

Mounting arrangement IM1001 (B3) – frames 355-400L

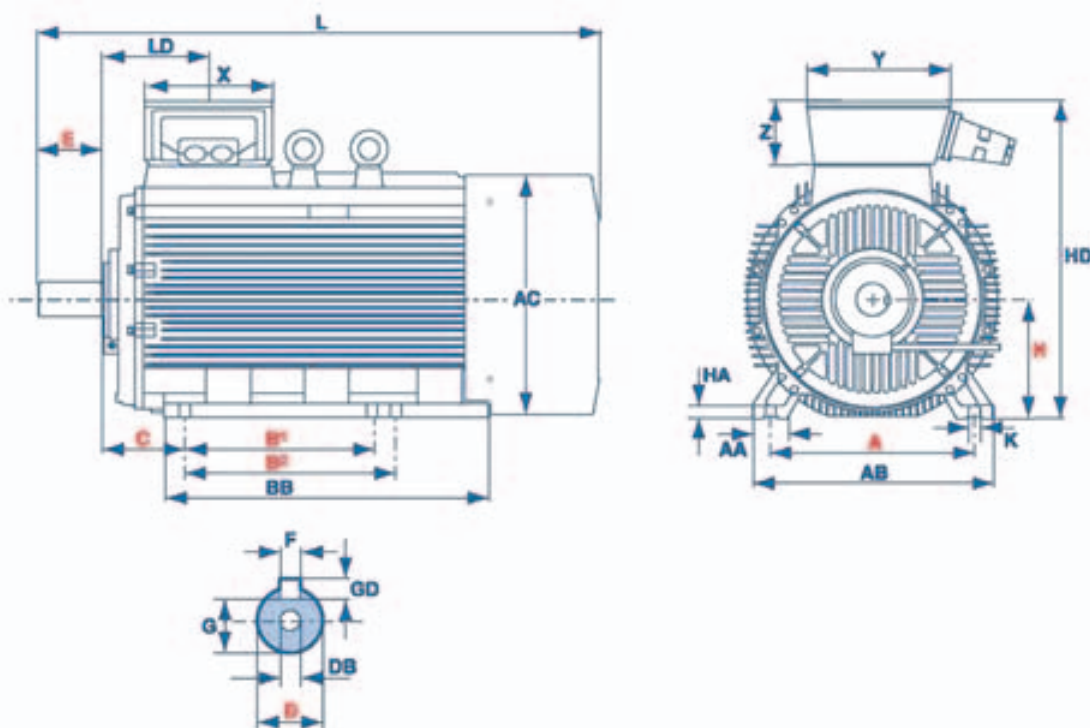

Dimensions in mm																		
Type	Pole	A	AA	AB	AC	B1	B2	C	D	E	H	HA	K	L	BB	HD	LC	LD
AD 355M	2	610	120	730	700	500	560	254	80m6	170	355	52	28	1555	750	970	1700	285
AD 355M	4-8					100m6	210		1595	1770								
AD 355Mx / My	6-8					500	560		100m6	210				1595			1770	
AD 355L / Lx / Ly	2					80m6	170		1555	1700								
AD 355L / Lx / Ly	4-8					100m6	210		1595	1770								
AD 400M / Mx / L	2	686	120	810	860	710	800	280	80m6	170	400	45	35	1850	1100	1090	1995	360
AD 400M / Mx / L	4-8					110m6	210		1925	2100								

Terminal box size 355 & 400 with "elephant nose" execution

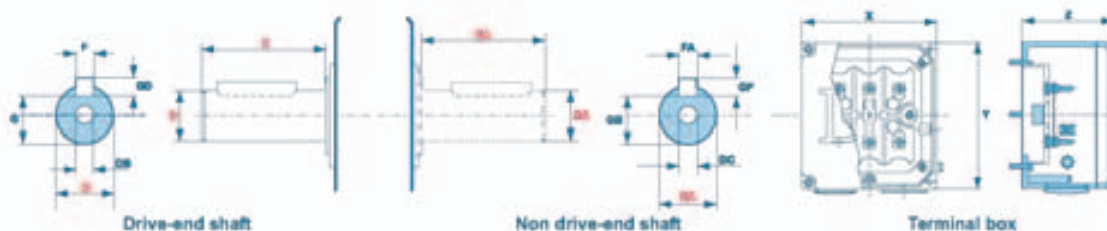

Dimensions in mm																		
Type	Pole	D	E	F	G	DB	GD	DA	EA	FA	GB	DC	GF	Eyebol	IPÉ*	X	Y	Z
AD 355M	2	80m6	170	22	71	M20	14	80m6	170	22	71	M20	14	M36	2 x Ø70mm* 1xM20x1,5(PTC)	360	487	200
AD 355M	4-8	100m6	210	28	90	M24	16	100m6	210	28	90	M24	16					
AD 355Mx / My	6-8	100m6	210	28	90	M24	16	100m6	210	28	90	M24	16					
AD 355L / Lx / Ly	2	80m6	170	22	71	M20	14	80m6	170	22	71	M20	14					
AD 355L / Lx / Ly	4-8	100m6	210	28	90	M24	16	100m6	210	28	90	M24	16					
AD 400M / Mx / L	2	80m6	170	22	71	M20	14	80m6	170	22	71	M20	14	2xM36	2xØ100mm** 1xM20x1,5(PTC)	430	485	225
AD 400M / Mx / L	4-8	110m6	210	28	100	M24	18	110m6	210	28	100	M24	18					

*Terminal box 355: +3 x M63x1,5

** Terminal box 400: +7 x M63x1,5

Informations given in tables are indicative, certified values are available on request.

SICMEMOTORI reserves the right to modify designing, technical features and dimensions without prior notice.

Mounting arrangement IM2001 (B35) – frames 355-400L

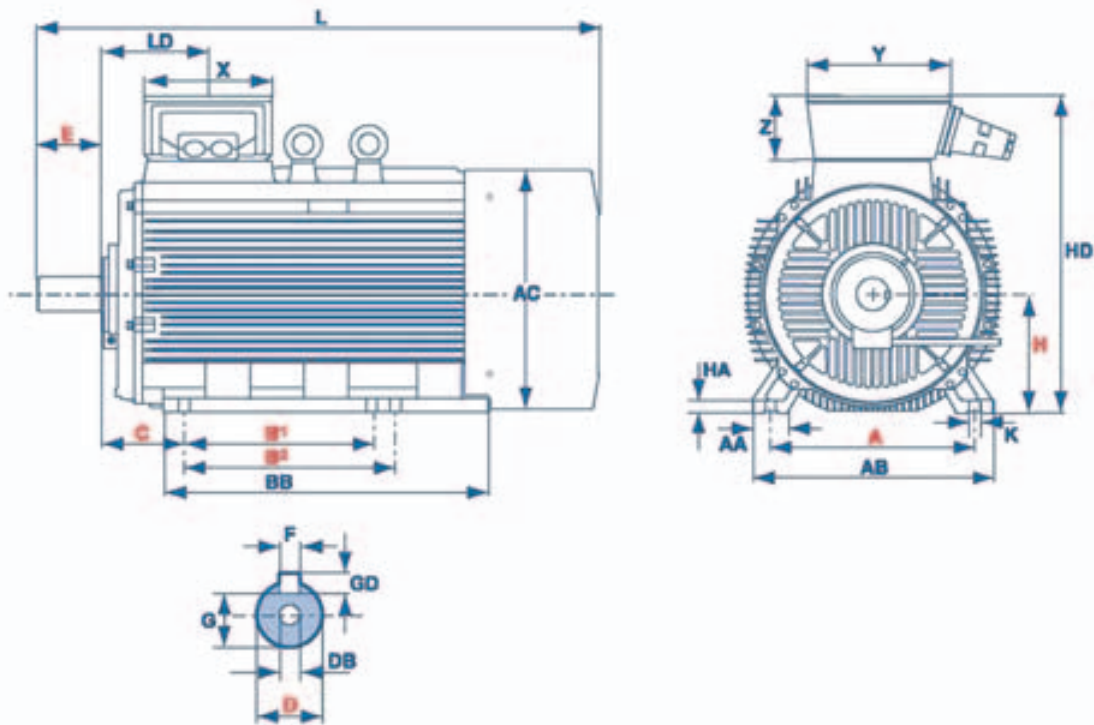

Dimensions in mm																			
Type	Pole	A	AA	AB	AC	B1	B2	C	D	E	H	HA	K	L	BB	HD	LC	LD	LA
AD 355M	2					500	560		80m6	170				1555			1700		
AD 355M	4-8								100m6	210				1595			1770		
AD 355Mx / My	6-8	610	120	730	700	500	560	254	100m6	210	355	52	28	1595	750	970	1770	285	25
AD 355L / Lx / Ly	2								80m6	170				1555			1700		
AD 355L / Lx / Ly	4-8					560	630		100m6	210				1595			1770		
AD 400M / Mx / L	2								80m6	170				1850			1995		
AD 400M / Mx / L	4-8	686	120	810	860	710	800	280	110m6	210	400	45	35	1925	1100	1090	2100	360	25

Dimensions in mm							
Type	Pole	Flange	M	N	P	S	T
AD 355M	2						
AD 355M	4-8						
AD 355Mx / My	6-8	FF 740	740	680	800	8xØ24	6
AD 355L / Lx / Ly	2						
AD 355L / Lx / Ly	4-8						
AD 400M / Mx / L	2						
AD 400M / Mx / L	4-8	FF 940	940	880	1000	8xØ28	6

Informations given in tables are indicative, certified values are available on request.

SICMEMOTORI reserves the right to modify designing, technical features and dimensions without prior notice.

Mounting arrangement IM3011 (V1) – frames 355-400L

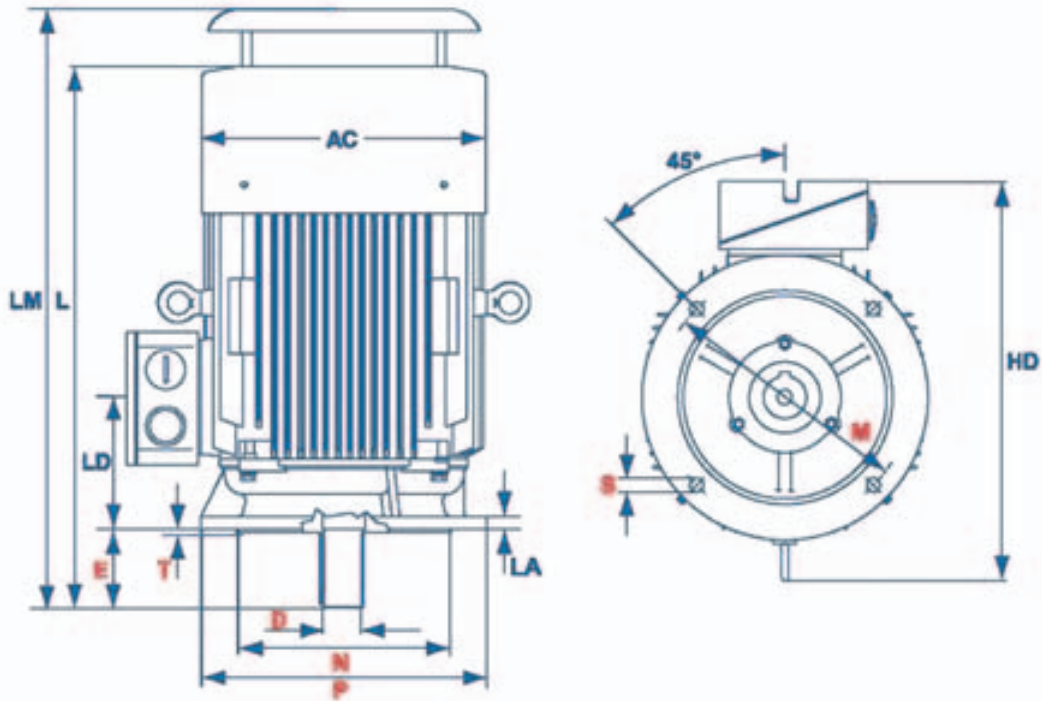

Dimensions in mm															
Type	Pole	AC	D	E	HD	L	LM	LA	LD	Flange	M	N	P	S	T
AD 355M	2	700	80m6	170	970	1555	1695	25	285	FF 740	740	680	800	8xØ24	6
AD 355M	4 – 8		100m6	210		1595	1740								
AD 355M x / My	6 - 8		100m6	210		1595	1740								
AD 355L / Lx / Ly	2		80m6	170		1555	1695								
AD 355L / Lx / Ly	4 – 8		100m6	210		1595	1740								
AD 400M / Mx / L	2	860	80m6	170	1150	1850	2150	25	360	FF 940	940	880	1000	8xØ28	6
AD 400M / Mx / L	4-8		110m6	210		1925	2220								

Informations given in tables are indicative, certified values are available on request.

SICMEMOTORI reserves the right to modify designing, technical features and dimensions without prior notice.

Mounting arrangement IM1001 (B3) – frames 400Lx-560

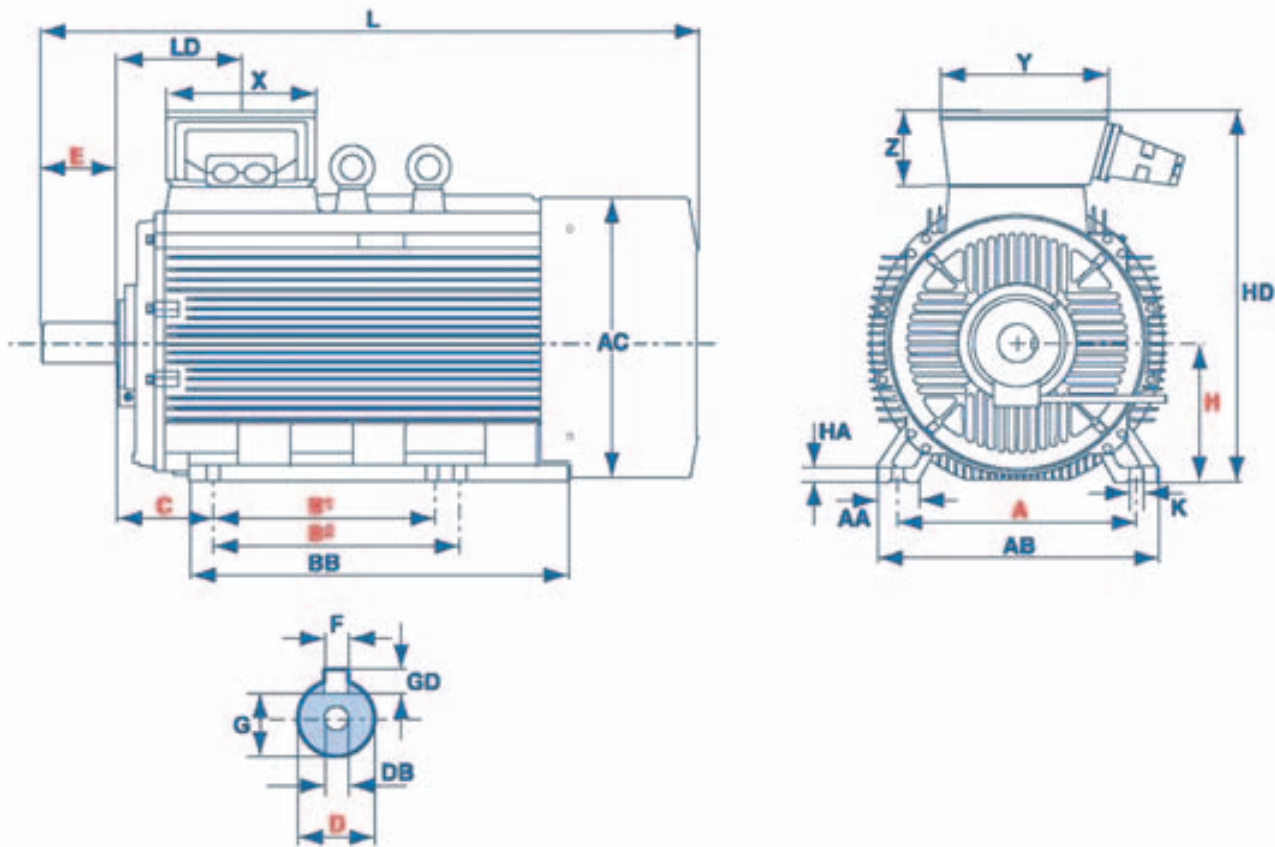

Dimensions in mm						
Type	Pole	Eyebolt	IPE	X	Y	Z
AD 400 Lx / Ly	2	2xM36	2xØ 100mm* 1 x M20x1,5 (PTC)	430	545	250
AD 400 Lx / Ly	4 - 8					
AD 450 M / Mx	2	2xM42	7 X M63x1,5 1 x M20x1,5 (PTC)	660	770	300
AD 450 M / Mx	4 - 8					
AD 450 L / Lx / Ly	2					
AD 450 L / Lx / Ly	4 - 8					
AD 500 M	4 - 8	2xM42	7 X M63x1,5 1 x M20x1,5 (PTC)	660	770	300
AD 500 L / Lx						
AD 560 M	4 - 8	2xM56	7 X M63x1,5 1 x M20x1,5 (PTC)	660	770	300
AD 560 L / Lx						

*Terminal box AD 400: +7 x M63x1,5

Dimensions in mm																				
Type	Pole	A	AA	AB	B	B1	B2	C	D	E	H	HA	K	L	BB	HD	F	G	GD	LD
AD 400 Lx / Ly	2	686	160	810	710	800	900	280	80m6	170	400	45	35	1880	1120	1100	22	71	14	362
AD 400 Lx / Ly	4 - 8								110m6	210				1925			28	100	16	
AD 450 M / Mx	2	800	225	980	900	1000	1120	280	95m6	170	450	45	35	2360	1495	1310	25	86	14	440
AD 450 M / Mx	4 - 8								120m6	210				2400			32	109	18	
AD 450 L / Lx / Ly	2								95m6	170				2360			25	86	14	
AD 450 L / Lx / Ly	4 - 8								120m6	210				2400			32	109	18	
AD 500 M	4 - 8	900	180	1080	1120	---	---	315	140m6	250	500	65	42	2520	1600	1365	36	128	20	412
AD 500 L / Lx									160m6	300							560	76	42	
AD 560 M	4 - 8	1000	210	1170	1400	---	---	355	160m6	300	560	76	42	2650	1680	1480	40	147	22	410
AD 560 L / Lx									160m6	300							560	76	42	

Informations given in tables are indicative, certified values are available on request.

SICMEMOTORI reserves the right to modify designing, technical features and dimensions without prior notice.

Mounting arrangement IM2001 (B35) – frames 400Lx-560

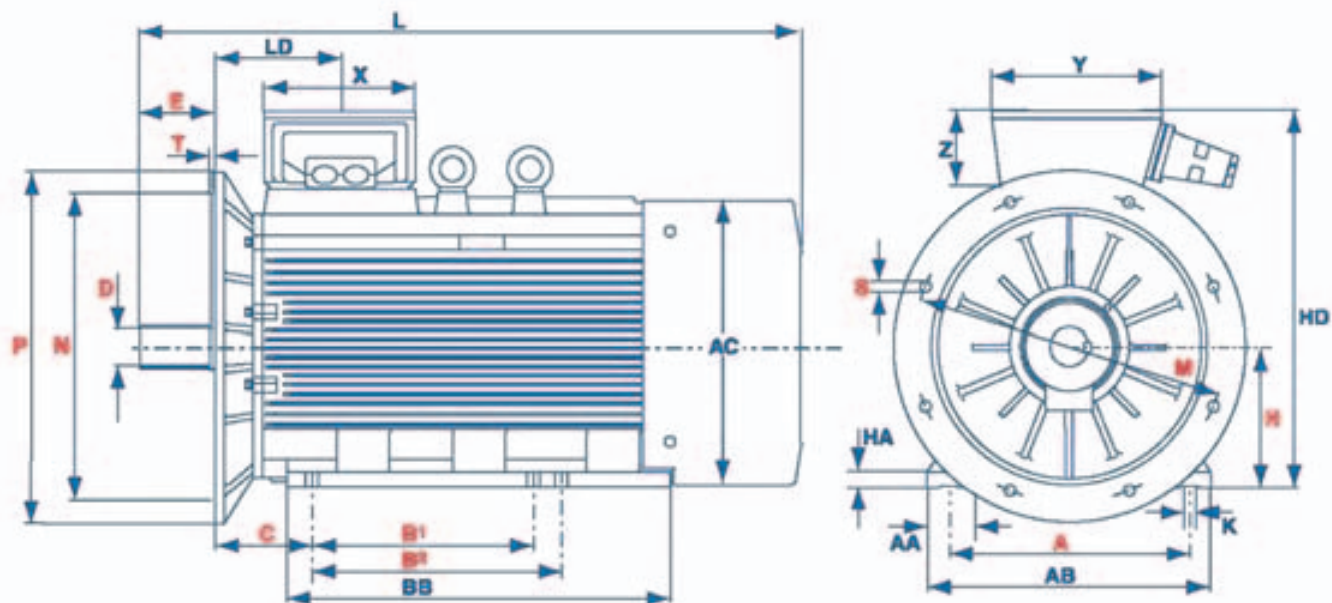

Dimensions in mm						
Type	Pole	Eyebolt	IPE	X	Y	Z
AD 400 Lx / Ly	2	2xM36	2xØ 100mm* 1 x M20x1,5 (PTC)	430	545	250
AD 400 Lx / Ly	4 - 8					
AD 450 M / Mx	2	2xM42	7 X M63x1,5 1 x M20x1,5 (PTC)	660	770	300
AD 450 M / Mx	4 - 8					
AD 450 L / Lx / Ly	2					
AD 450 L / Lx / Ly	4 - 8					
AD 500 M	4 - 8	2xM42	7 X M63x1,5 1 x M20x1,5 (PTC)	660	770	300
AD 500 L / Lx						
AD 560 M	4 - 8	2xM56	7 X M63x1,5 1 x M20x1,5 (PTC)	660	770	300
AD 560 L / Lx						

*Terminal box AD 400: +7 x M63x1,5

Dimensions in mm																				
Type	Pole	A	AA	AB	B	B1	B2	C	D	E	H	HA	K	L	LD	M	N	P	S	T
AD 400 Lx / Ly	2	686	160	810	710	800	900	280	80m6	170	400	45	35	1880	362	940	880	1000	8xØ28	6
AD 400 Lx / Ly	4 - 8								110m6	210				1925						
AD 450 M / Mx	2	800	225	980	900	1000	1120	280	95m6	170	450	45	35	2360	440	940	880	1000	8xØ28	6
AD 450 M / Mx	4 - 8								120m6	210				2400						
AD 450 L / Lx / Ly	2								95m6	170				2360						
AD 450 L / Lx / Ly	4 - 8								120m6	210				2400						
AD 500 M	4 - 8	900	180	1080	1120	---	---	315	140m6	250	500	65	42	2520	412	1080	1000	1150	8xØ28	6
AD 500 L / Lx									140m6	250				2520						
AD 560 M	4 - 8	1000	210	1170	1400	---	---	355	160m6	300	560	76	42	2650	410	1180	1120	1250	8xØ28	7
AD 560 L / Lx									160m6	300				2650						

Informations given in tables are indicative, certified values are available on request.

SICMEMOTORI reserves the right to modify designing, technical features and dimensions without prior notice.

Mounting arrangement IM3011 (V1) – frames 400Lx-560

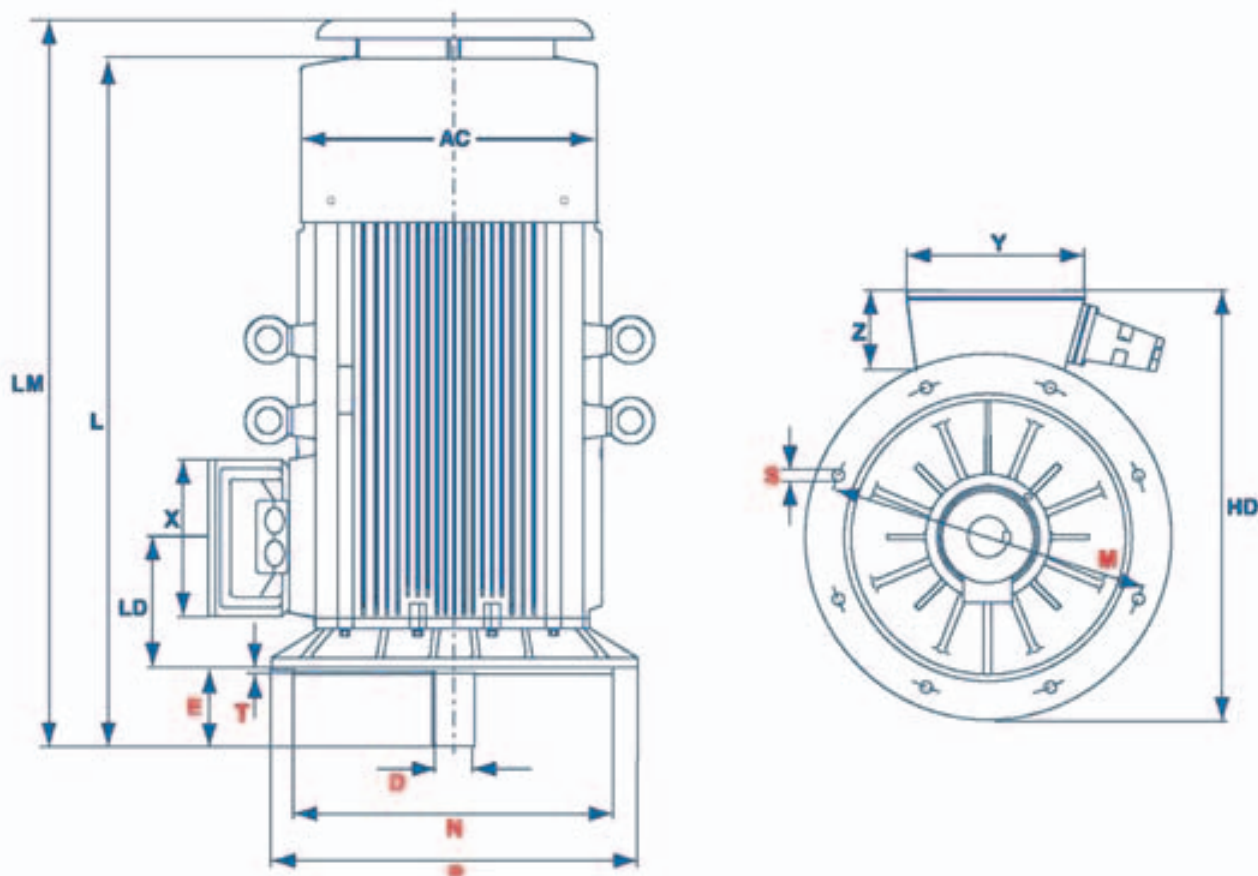

Dimensions in mm						
Type	Pole	Eyebolt	IPE	X	Y	Z
AD 400 Lx / Ly	2	2xM36	2xØ 100mm* 1 x M20x1,5 (PTC)	430	545	250
AD 400 Lx / Ly	4 - 8					
AD 450 M / Mx	2	2xM42	7 X M63x1,5 1 x M20x1,5 (PTC)	660	770	300
AD 450 M / Mx	4 - 8					
AD 450 L / Lx / Ly	2					
AD 450 L / Lx / Ly	4 - 8					
AD 500 M	4 - 8	2xM42	7 X M63x1,5 1 x M20x1,5 (PTC)	660	770	300
AD 500 L / Lx						
AD 560 M	4 - 8	2xM56	7 X M63x1,5 1 x M20x1,5 (PTC)	660	770	300
AD 560 L / Lx						

*Terminal box AD 400: +7 x M63x1,5

Dimensions in mm													
Type	Pole	AC	D	E	H	HD	L	LM	M	N	P	S	T
AD 400 Lx / Ly	2	865	80m6	170	400	1275	1880	2230	940	880	1000	8xØ28	6
AD 400 Lx / Ly	4 - 8		110m6	210			1925	2275					
AD 450 M / Mx	2	1035	95m6	170	450	1536	2360	2710	940	880	1000	8xØ28	6
AD 450 M / Mx	4 - 8		120m6	210			2400	2750					
AD 450 L / Lx / Ly	2		95m6	170			2360	2710					
AD 450 L / Lx / Ly	4 - 8		120m6	210			2400	2750					
AD 500 M	4-8	1095	140m6	250	500	1576	2520	2870	1080	1000	1150	8xØ28	6
AD 500 L / Lx													
AD 560 M	4-8	1195	160m6	300	560	1681	2650	3000	1180	1120	1250	8xØ28	7
AD 560 L / Lx													

Informations given in tables are indicative, certified values are available on request.

SICMEMOTORI reserves the right to modify designing, technical features and dimensions without prior notice.

Motors with independent axial ventilation IC 416

When wide constant torque speed regulation is required, an independent axial fan can be assembled, with separate supply, to guarantee an efficient motor cooling at low speed.

The assembling of a hollow shaft pulse generator can also be done.

The degree of protection of the whole motor is still IP55.

The fan cover is in steel, the fan blades are as indicated in tables of main constructive figures.

Auxiliary blowers data – Cast iron body					
Frame	Power W	Current A max	Speed rpm	Noise level dBA	Weight kg
355	650	0.91	1500/1800	75	30
400	650	0.91	1500/1800	76	40
450	650	0.91	1500/1800	76	48
500	1100	1.9	1050	77	55
560	1100	1.9	1050	77	65

Pulse generator

A hollow shaft (15 mm diameter) pulse generator can be assembled to control the motor speed; usually, pulse generator terminals are loose. **SICMEMOTORI** can supply the following pulse generators:

Pulses per rev.	Electronic	Supply	Signals voltage	Type
1024*	HTL	4,5÷32Vdc	11-30Vdc	VFS60
1024*	TTL	4,5÷32Vdc	5Vdc	VFS60

*Pulses per revolutions can be programmed in the range 526÷4096ppr

Other pulse generators, with same fixing dimensions, can be assembled by the customer itself.

Maximum speed

When used with an inverter, motors can be asked to work at speed higher than the nominal one.

The following table gives the max mechanical speed for the motors of this catalogue.

Type	Pole Nr.	Max speed (rpm)
AD 355	2	3800
	4	3100
	6	3100
	8	3100
AD 400	2	3500
	4-6-8	2500
AD 450	2	3200
	4	2100
	6-8	1900
AD 500	4	1900
	6	1800
	8	1700
AD 560	4	1800
	6	1800
	8	1800

Informations given in tables are indicative, certified values are available on request.

SICMEMOTORI reserves the right to modify designing, technical features and dimensions without prior notice

Mounting arrangement IM1001 (B3)- IC416 forced ventilation - Frames 355-560

The following drawing shows the main approximative dimensions for motors with independent axial forced ventilation. Please ask SICMEMOTORI for certified drawings.

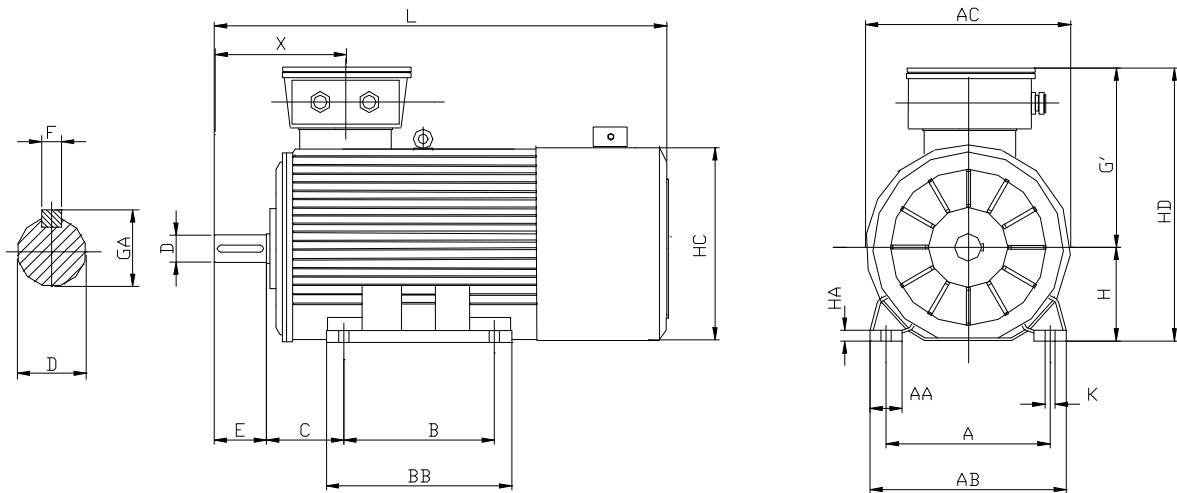

Type	pole	H	L	HC	HD
AD 355 M-Mx-My	2	355	1735	700	970
AD 355 M-Mx-My	4 - 8		1775		
AD 355 L-Lx-Ly	2		2085		
AD 355 L-Lx-Ly	4 - 8		2124		
AD 400 M-Mx-L	2	400	1965	860	1090
AD 400 M-Mx-L	4 - 8		2025		
AD 400 Lx-Ly-Lz	2		2115	865	1100
AD 400 Lx-Ly-Lz	4 - 8		2175		
AD 450 M-Mx	2	450	2435	1032	1310
AD 450 M-Mx	4 - 8		2475		
AD 450 L-Lx-Ly-Lz	2		2435		
AD 450 L-Lx-Ly-Lz	4 - 8		2475		
AD 500 M-L-Lx	4 - 8	500	2705	1095	1365
AD 560 M-L-Lx	4 - 8	560	2758	1195	1480

For other dimensions please refer to dimensional drawings

Informations given in tables are indicative, certified values are available on request.

SICMEMOTORI reserves the right to modify designing, technical features and dimensions without prior notice.

Terminal box and cable glands

Terminal box has IP55 degree of protection (provided that supply cable connection is properly made).

The terminal board is normally equipped with 6 terminals, and it is made with non hygroscopic and anti-mold material.

Generally, cable-glands with following dimensions are provided:

Type	Current Amps	Dimensions in mm				
		L	B	H	S	T
AD 355	750	Ø260		110	216	M16
AD 400	1400	290	290	70	260	M16
AD 450	1500	496	290	63	460	M16
AD 500	1625					
AD 560	1700					

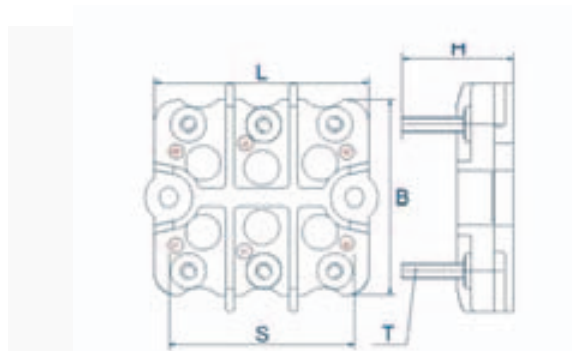

Tolerances

Operating characteristics are guaranteed with the tolerances defined by IEC 60031-1 Standards, as showed in the following table.

Characteristics	Tolerances
Efficiency	Motor power ≤ 50 kW: -15% of (1 - η) Motor power > 50 kW: -10% of (1 - η)
Power factor	+1/6 (1 - cosφ) Min 0.02 Max 0.07
Locked rotor current	+20% of guaranteed value
Locked rotor torque	-15% + 25% of guaranteed value
Pull out torque	-20% of guaranteed value
Slip	Power motor < 1 kW: ± 30% of guaranteed value Power motor ≥ 1 kW: ± 20% of guaranteed value

Available options (with overprice)

Option	
IC416 kit with encoder provision	YES
Encoder (hollow shaft)	YES
Terminal box right, left, DE view	YES
2nd power shat end	YES
NDE insulated bearing	YES (compulsory for inverter duty)
PTC (150 °C)	Standard
Klixon, Pt100	YES
DE roller bearing	YES
Pt100 in bearings	YES
Special balancing	YES
Other supply voltage/frequency	YES
Other mounting arrangements	YES
Anticondensation heaters	YES
Special painting for saline env.	YES

Informations given in tables are indicative, certified values are available on request.

SICMEMOTORI reserves the right to modify designing, technical features and dimensions without prior notice

Permissible radial loads for horizontal and vertical motors (F_R)

The following table gives the permissible radial force in N, assuming zero axial force ** and standard ball bearings. In case of higher radial force than given in the table an enforced bearing must be used. The values are based on normal conditions at 50Hz and calculated for 20.000 working hours for 2 pole motors and 40.000 hours for 4, 6 and 8 pole motors. For 60Hz, the values must be reduced by 10%.

Maximum radial force (F_R)				
Type	Pole	N		
		X_c	$X_{1/2}$ mm	X_{Max}
AD 355*	2	16330	15390	8730
	4	28300	25860	14290
	6	32400	29600	16350
	8	35660	32580	18000
AD 400*	2			
	4	33730	31140	19280
	6	38610	35650	22070
	8	42500	39240	24290
AD 450 AD 500 AD 560	2 4 6 8	Please ask SICMEMOTORI		

*Standard motors with enforced bearing arrangement

** In case F_A and F_R apply both please contact SICMEMOTORI

Pulley diameter

When the desired bearing life has been calculated, the **minimum pulley diameter** can be calculated with the following formula:

$$D = (1,9 \times 10^7 \times k \times P_N) / (n_N \times F_{RX} (X_0 / X_{1/2} \text{ } \gamma \text{ } X_{max}))$$

- D : diameter of the pulley (mm)
- P_N : power of the motor (kW)
- n_N : motor rated speed (rpm)
- k : belt tension factor (k=2-2,5 for V-belts)
- F_{RX} : permissible radial force

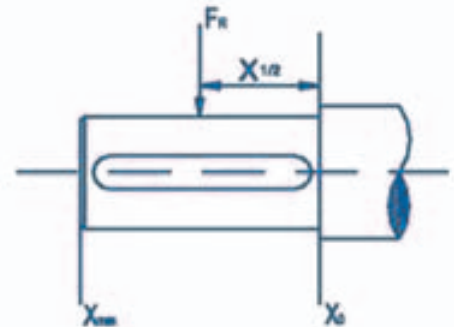

In case of higher radial force than given in the table an enforced bearing must be used. The values are based on normal conditions at 50Hz and calculated for 20.000 working hours for 2 pole motors and 40.000 hours for 4, 6 and 8 pole motors. For 60Hz, the values must be reduced by 10%.

Permissible axial loads for horizontal and vertical motors (F_A)

The following table gives the permissible axial force in N, assuming zero radial force **. In this case motors must be ordered with standard bearings. In case of higher axial force than given in the table an angular contact bearing must be used. The values are based on normal conditions at 50Hz and calculated for 20.000 working hours for 2 pole motors and 40.000 hours for 4, 6 and 8 pole motors. For 60Hz, the values must be reduced by 10%.

$F_{pressure}$ is calculated for a fixed bearing at the DE.

Maximum axial force (F_A)					
Type	Pole	N			
		B3 $F_{Pressure}$	B3 F_{pull}	V1 $F_{Pressure}$	V1 F_{pull}
AD 355	2	6100	1850	14000	800
	4	9800	3900	18300	2500*
	6	10500	4700	20700	3500*
	8	12500	6000	21500	3600*
AD 400	2				
	4	11200	3900	18500	1600*
	6	12500	4800	19500	2200*
	8	12800	4950	21500	2900*
AD 450 AD 500 AD 560	2 4 6 8	Please ask SICMEMOTORI			

*data calculated on 20.000 working hours

** In case F_A and F_R apply both please contact SICMEMOTORI

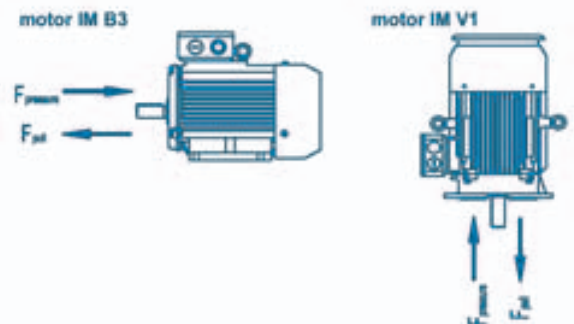

Motor spare parts list / Sectional drawing

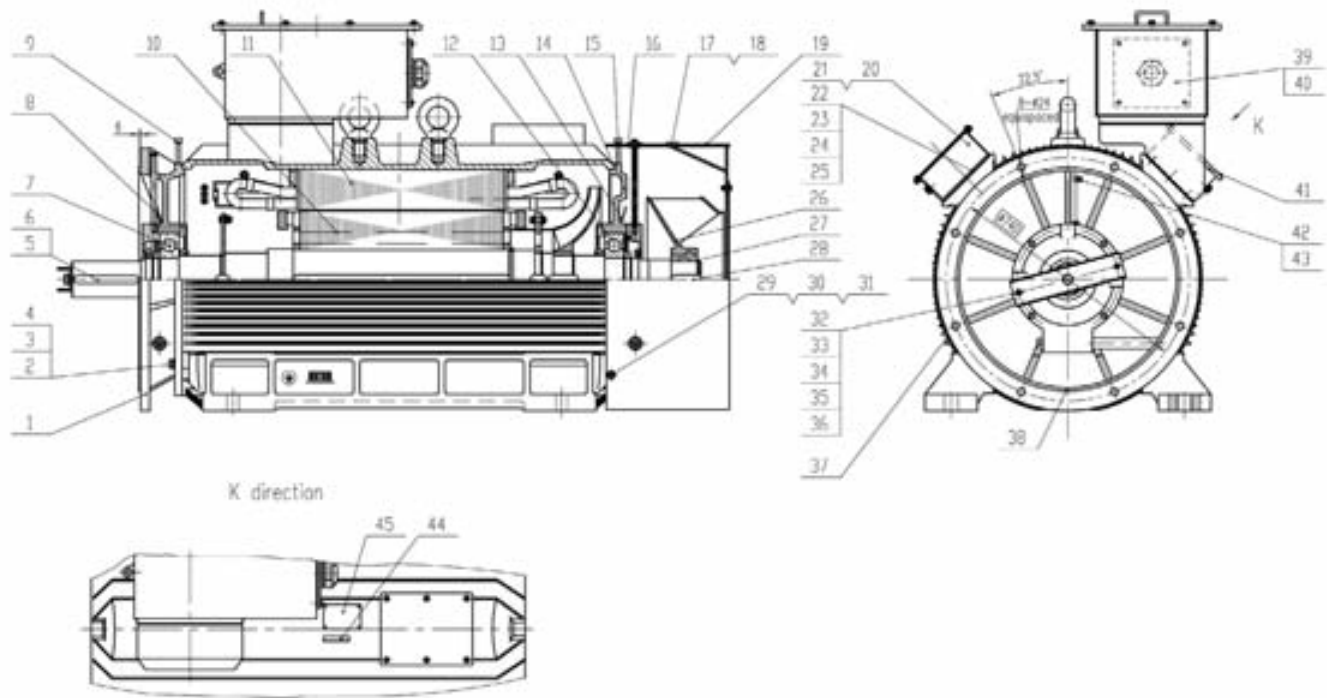

1	DE shield	24	Cover plate
2	Bolt	25	Rubber seal
3	Washer	26	Fan
4	Washer	27	Circlip
5	Shaft sleeve	28	Key
6	Key	29	Bolt
7	DE bearing assembly	30	Washer
8	Pt100 for DE bearing	31	Washer
9	DE SPM nipple	32	Screw
10	Rotor	33	Shaft protector
11	Stator	34	Nut
12	NDE bearing assembly	35	Bolt
13	PT100 for NDE bearing	36	Washer
14	NDE shield	37	Plug
15	NDE SPM nipple	38	Condense hole plug
16	Plug through-hole	39	Joint part
17	Rotation label	40	Terminal box
18	Rivet	41	Connection diagram
19	Fan cover	42	Clamp
20	Small terminal box	43	Bolt
21	Connection diagram	44	Sticker
22	Bolt	45	Nameplate
23	Washer		

Main constructive figures

	Frame	355	400	450	500	560
Casing	Material	Cast iron				
Stator	Material	Lamination				
	Feet	Fixed				
End shields	Material	Cast iron				
Flanges	Material	Cast iron				
Bearings	DE	Ball or roller bearings				
	NDE	Ball bearings				
	Lubrication	Grease				
Terminal box	Material	Cast iron				
Fan blades	Material	Plastic	Aluminium			
Fan cover	Material	Steel				
Name plate	Material	Steel				
Stator winding	Material	Copper with special insulation for inverter duty				
Rotor	Material	Lamination + die-caste aluminium**				
Shaft	Material	Steel				
PTC thermistors (150 °C)		Standard				
Cooling IC416 *		Steel (on request)				
Insulated NDE bearing		Compulsory for inverter duty motors				

* on request (with mounting kit)

** when V>500V, copper bars can be used

Products listed in this catalogue are exclusively designed and built for industrial purposes.

For particular cases in NON-industrial environments, or where other types of protection must be provided (for example against contact with children fingers, etc.), these guards or additional protections must be realized by the Customer.

Any non-observance of the rules for installation, use and maintenance or any modification/tampering with the motor makes the guarantee rights invalid and exempts SICMEMOTORI from any responsibility

All data and indications shown in this catalogue have to be considered only as a guideline.

Any use of the motor differently from the specifications indicated in this catalogue does not involve any liability for SICMEMOTORI as manufacturer

SICMEMOTORI reserves the right to modify at any time and without notice the data, the technical characteristics, the dimensions, the weights and the illustrations.

SICMEMOTORI refuses all responsibility for direct or indirect damages caused by possible errors and/or omissions in the present catalogue

The reproduction, even in part, of the present catalogue must be authorized in writing by SICME MOTORI srl.

SICME MOTORI srl. All rights reserved



WARNING

The motors and the electrical devices feeding them are electrical components installed on machines and industrial systems subject to high voltage. During operation, these components can be dangerous since they are live, they can have non-insulated and rotating parts and they can reach high temperatures. Therefore, they can be extremely harmful to personnel and objects if the instructions for the installation, the use and the maintenance are not respected.

The motors are always supplied complete with the installation, use and maintenance instruction manual. It is necessary to read and understand all the information contained before proceeding to connect and to start up the installation. If the abovementioned documentation is lacking, please ask a copy to SICMEMOTORI.



SICMEMOTORI

SICME MOTORI S.r.l.

Str. Del Francese, 130 - 10156 Torino - Italia

Tel. +39 011 4076311 Fax +39 011 4500047 / 4500367

www.sicmemotori.com - sicmemotori@sicmemotori.com

