

QUESTO MOTORE PUO' FUNZIONARE NELLE SEGUENTI FORME COSTRUTTIVE:
 THIS MOTOR CAN WORK IN THE FOLLOWING MOUNTING ARRANGEMENTS:
 CET MOTEUR PEUT FONCTIONNER DANS LES SUIVANTES FORMES DE CONSTRUCTION:

B3	-	IM 1001	V5	-	IM 1011
V6	-	IM 1031	V15	-	IM 2011
V36	-	IM 2031	B75	-	IM 2061
B65	-	IM 2051	V1	-	IM 3011

MASSA TOTALE MOTORE
 TOTAL WEIGHT MOTOR
 MASSE TOTALE MOTEUR
 = 730 kg

MOMENTO DI INERZIA
 MOMENT OF INERTIA
 MOMENT D'INERTIE
 = 1.26 kgm²

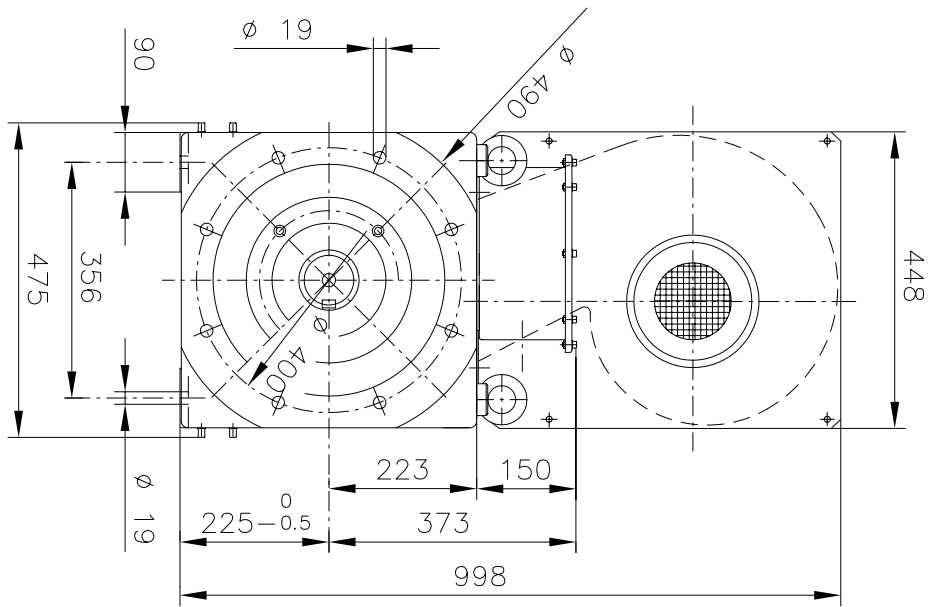
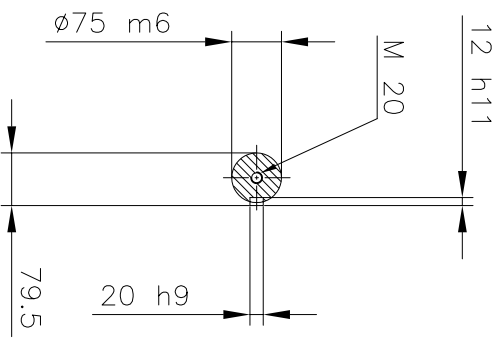
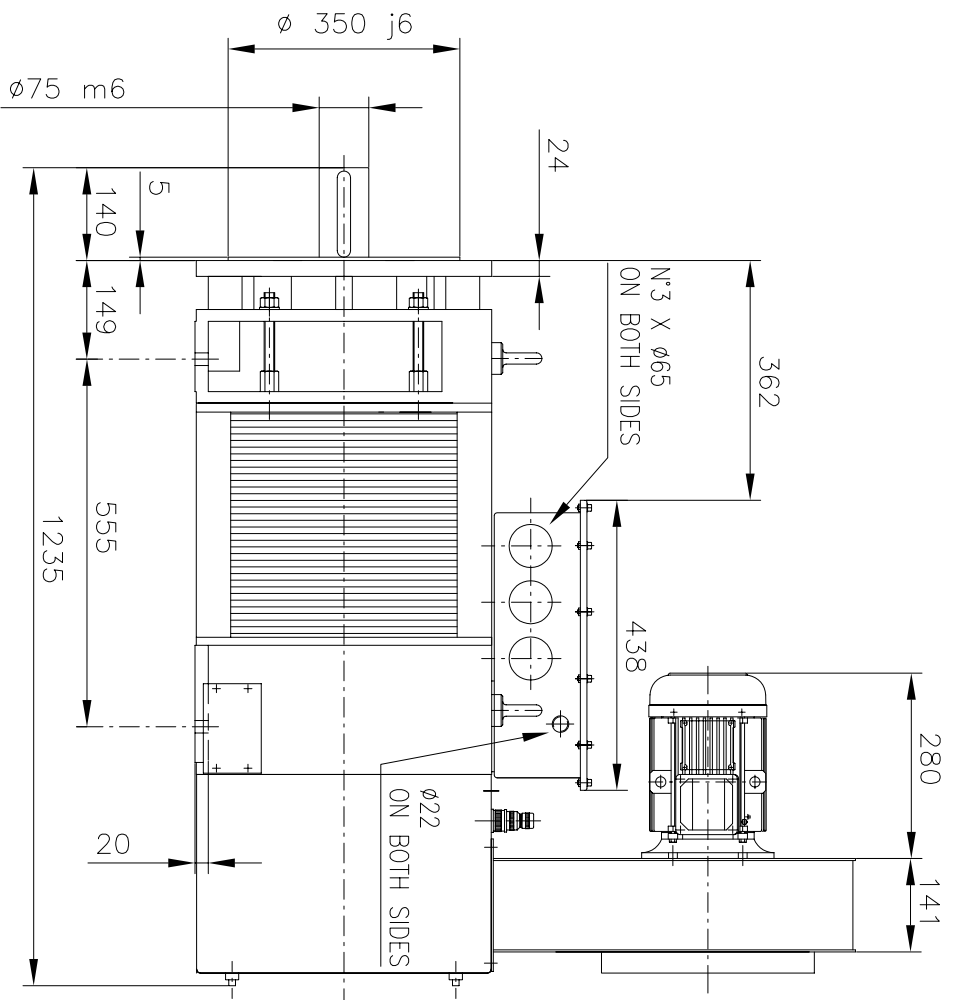

Modifiche :
 OUTLINE A.C. MOTOR TYPE AQC(BQC) 225 S CVER/B35
 TERMINAL BOX ON THE TOP
 IC 416 - IM 2001 - MOTOR AND TERMINAL BOX IP54(55)
 ENCOMBREMENT MOTEUR A C.A. TYPE AQC(BQC)225 S CVER/B35
 BOITE A BORNES EN HAUT
 IC 416 - IM 2001 - MOTEUR, BOITE A BORNES IP54(55)
 VENTILATEUR IP54

INGOMBRO MOTORE A C.A. TIPO AQC(BQC) 225 S CVER/B35
 SCATOLA CAVI IN ALTO
 IC 416 - IM 2001 - MOTORE E SCATOLA CAVI IP54(55)
 A TERMINE DI LEGGE CI RISERVAMO LA PROPRIETA' DI QUESTO DISEGNO CON IL DIVIETO DI
 RIPRODURLO O DI RENDERSI NOTO A TERZI SENZA LA NOSTRA AUTORIZZAZIONE.

1 : 1

Firma

Disegn. 27/

Controll. Visto

03/

MOD. 1



N° DIS. DRAW. N°

R T2

1

TA

700